

features

- Axial Format
- Up to 10A I_{DC}
- 4.7 μ H to 1.5mH
- Low DC Resistance
- Fully Tinned Leads
- MIL-I-23053/5 Class III Sleeving
- Supplied in Packs of 10
- Custom Parts Available

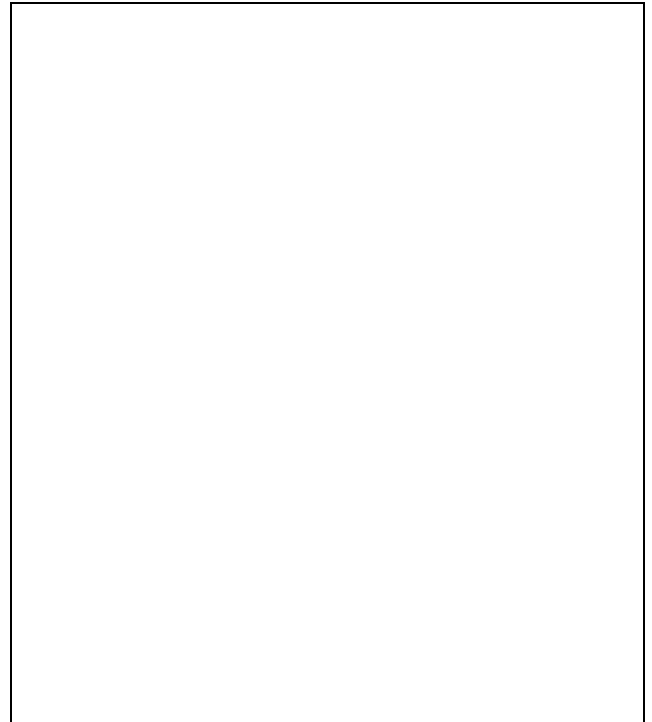

description

The 1200 Series is a range of general purpose inductors which are intended for use where high I_{DC} capability is required in a low cost product. Two series are available, offering high I_{DC} or small size.

schematic

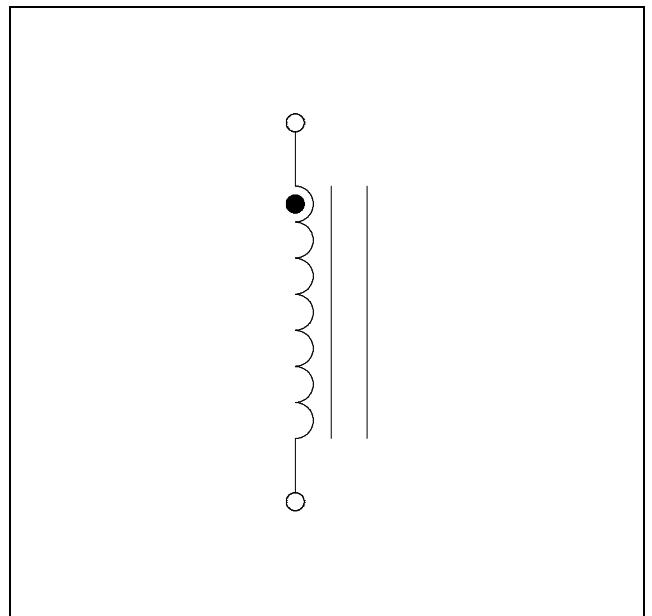

3 1200 SERIES

absolute maximum ratings over operating free air temperature range

Operating free air temperature range	0°C to 70°C
Storage temperature range	-55°C to 125°C

1200 SERIES

Axial Lead Inductors

electrical characteristics over operating free air temperature range

standard types (Note : All data taken at TA=25°C)

Part Number	Inductance (±10%) (at 1kHz) μH	DC Resistance (max.) Ω	DC Current Continuous A	Nominal Q at f kHz		Nominal Self Resonant Frequency MHz
				Q	f	
1200/A	4.7	0.037	4.5	65	1000	30.2
1200/B	8.8	0.050	4.5	65	500	19.8
1200/C	10	0.056	4.0	65	500	18.1
1200/D	15	0.068	3.0	55	500	15.0
1200/E	22	0.087	3.0	50	500	10.9
1200/F	30	0.100	3.0	45	500	7.8
1200/1	47	0.140	2.0	55	100	5.0
1200/2	68	0.170	2.0	50	80	4.9
1200/3	88	0.200	2.0	50	50	4.8
1200/5	100	0.220	2.0	50	50	3.7
1200/6	120	0.240	2.0	50	50	3.2
1200/7	150	0.260	2.0	50	50	2.9
1200/8	180	0.310	1.75	50	50	2.5
1200/9	220	0.350	1.5	45	50	5.3
1200/10	270	0.380	1.25	45	50	1.8
1200/11	300	0.400	1.0	45	50	1.3
1200/12	390	0.450	1.0	50	30	1.2
1200/13	470	0.490	1.0	50	10	1.0
1200/14	680	0.630	1.0	50	10	0.9
1200/15	1.0mH	0.770	1.0	55	10	0.8
1200/16	1.2mH	0.880	1.0	50	10	0.7
1200/17	1.5mH	0.990	1.0	60	10	0.6

outline dimensions

standard types

Part Number	Outline Dimensions
	Øa (max.)
1200/A	8.5
1200/B	8.5
1200/C	8.5
1200/D	8.5
1200/E	8.5
1200/F	9.0
1200/1	9.0
1200/2	10.0
1200/3	10.0
1200/5	10.0
1200/6	10.0
1200/7	10.0
1200/8	10.0
1200/9	10.0
1200/10	10.0
1200/11	10.0
1200/12	11.0
1200/13	11.0
1200/14	12.0
1200/15	12.0
1200/16	13.5
1200/17	13.5

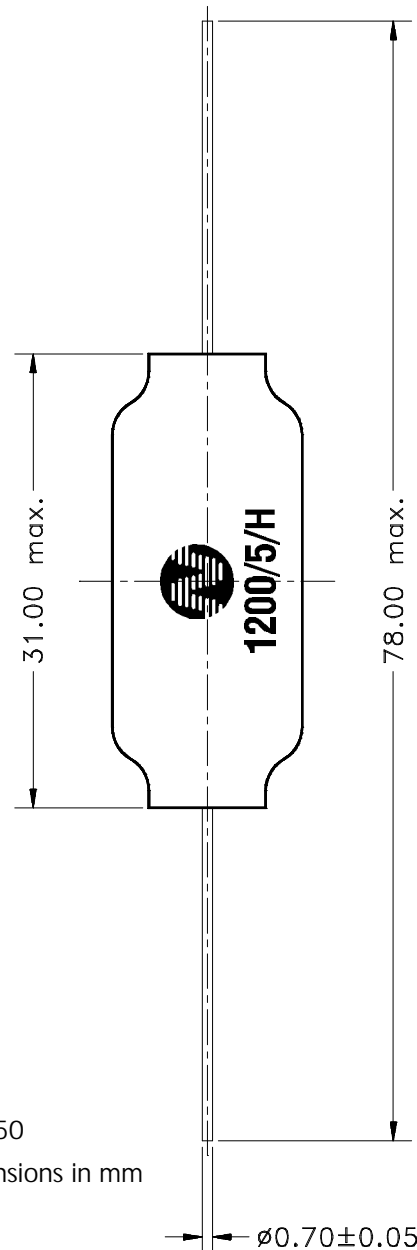
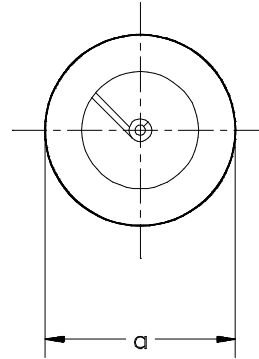

XX.X±0.50
All dimensions in mm

1200 SERIES

1200 SERIES

Axial Lead Inductors

electrical characteristics over operating free-air temperature range

high current types (Note : All data taken at TA=25°C)

Part Number	Inductance (±10%) (at 1kHz) μH	DC Resistance (max.) Ω	DC Current Continuous A	Nominal Q at f kHz		Nominal Self Resonant Frequency MHz
				Q	f	
1200/A/H	4.7	0.009	10.0	65	1000	22.7
1200/B/H	8.8	0.013	8.0	40	500	20.6
1200/C/H	10	0.0145	7.5	35	500	18.6
1200/D/H	15	0.0195	7.0	20	500	14.9
1200/E/H	22	0.025	6.5	20	500	13.0
1200/F/H	30	0.029	6.0	15	500	8.3
1200/1/H	47	0.0375	5.5	10	100	4.0
1200/2/H	68	0.046	4.85	10	80	3.7
1200/3/H	88	0.055	4.2	10	50	3.5
1200/5/H	100	0.060	4.0	10	50	3.0
1200/6/H	120	0.0675	3.95	10	50	2.8
1200/7/H	150	0.075	3.9	10	50	2.7
1200/8/H	180	0.0925	3.7	10	50	2.5
1200/9/H	220	0.110	3.5	8.6	50	2.4
1200/10/H	270	0.120	3.45	8.3	50	2.3
1200/11/H	300	0.130	3.4	7.8	50	2.2
1200/12/H	390	0.150	3.15	7.8	30	2.2
1200/13/H	470	0.170	2.9	7.7	10	2.1
1200/14/H	680	0.320	2.3	8.0	10	1.7
1200/15/H	1.0mH	0.470	1.7	41	10	1.1
1200/16/H	1.2mH	0.600	1.55	40	10	0.9
1200/17/H	1.5mH	0.730	1.4	47	10	0.8

outline dimensions

high current types

Part Number	Outline Dimensions
	Øa (max.)
1200/A/H	10.0
1200/B/H	10.0
1200/C/H	10.0
1200/D/H	12.0
1200/E/H	12.5
1200/F/H	12.5
1200/1/H	12.5
1200/2/H	13.0
1200/3/H	13.0
1200/5/H	13.0
1200/6/H	14.0
1200/7/H	16.0
1200/8/H	16.0
1200/9/H	16.5
1200/10/H	18.0
1200/11/H	19.0
1200/12/H	22.0
1200/13/H	22.0
1200/14/H	15.0
1200/15/H	17.0
1200/16/H	17.0
1200/17/H	17.0

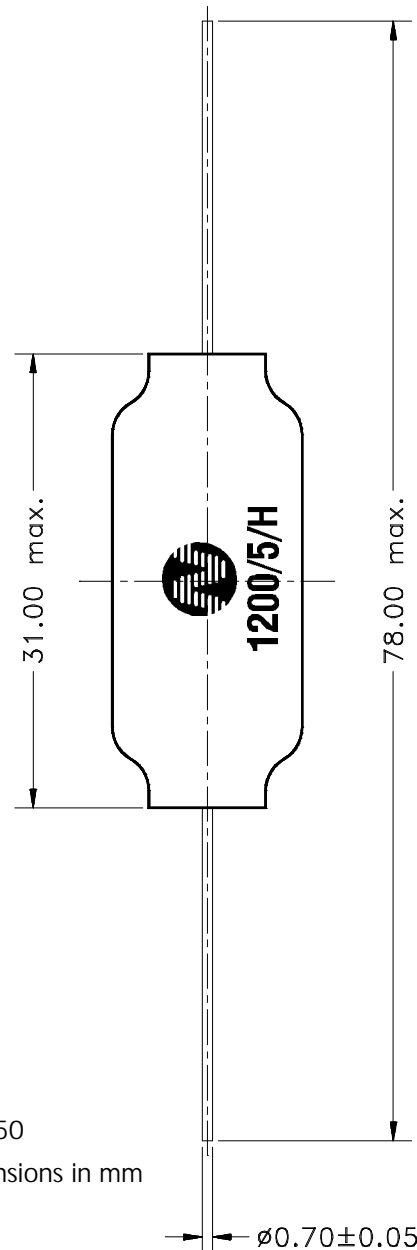
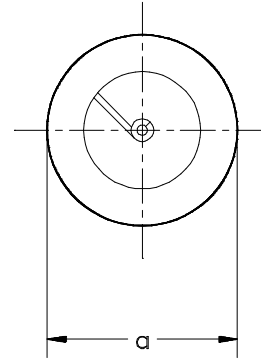

XX.X±0.50
All dimensions in mm

1200 SERIES

1200 SERIES

Axial Lead Inductors

typical core characteristics

Inductance Temperature Coefficient	Resistance Temperature Coefficient	Curie Temperature T_c	Saturation Flux B_{SAT}
125ppm	3900ppm	270°C	350mT